



Ultra Broadband SPST

FEATURES

- ❖ Low Insertion Loss
- ❖ Low VSWR
- ❖ High Isolation
- ❖ TTL Compatible Logic
- ❖ Miniaturized Package Available
- ❖ Wide Operating Temperature Range

SPECIFICATIONS

Ultra Broadband SPST						
Model Number	Frequency Range (GHz)	Insertion Loss (dB)	Isolation (dB)	Speed (ns)	VSWR	Type (R/S)
S1R0120-45T100	0.1-20	2.5	45	100	2.0:1	R
S1A0120-45T100	0.1-20	3.5	40	100	2.0:1	A
S1R0518-50T20	0.5-18	2.4	50	20	1.8:1	R
S1A0518-50T20	0.5-18	3.2	45	20	1.8:1	A

Note 1. Type R is for Reflective switches and type A is for Absorptive switches.

Note 2. DC requirement: ± 5 V at ± 75 mA

Note 3. Miniaturized package is SMA connector removable.

Note 4. Customer outline package and electrical specifications available on request.

Note 5. TTL compatible logic control, Logic "0" enables thru pass.

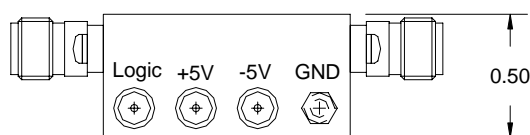
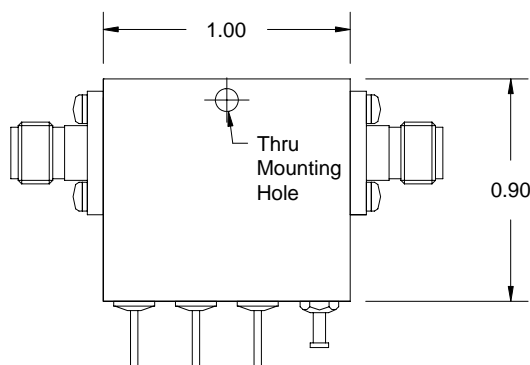

Standard SMA Package

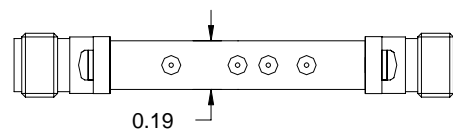
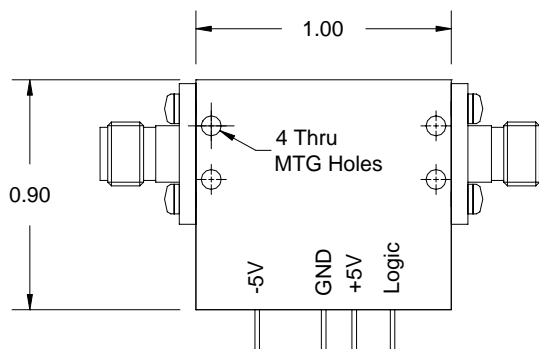

**Drop-in Removable Connectors
Miniaturized Package**